

GRAPA RÁPIDA VERTICAL · QUICK VERTICAL TOGGLE CLAMPS

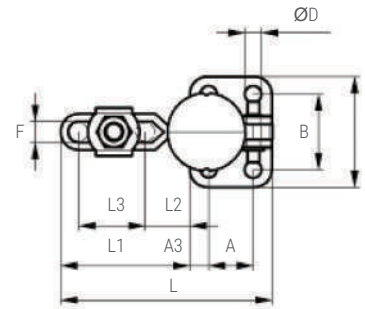
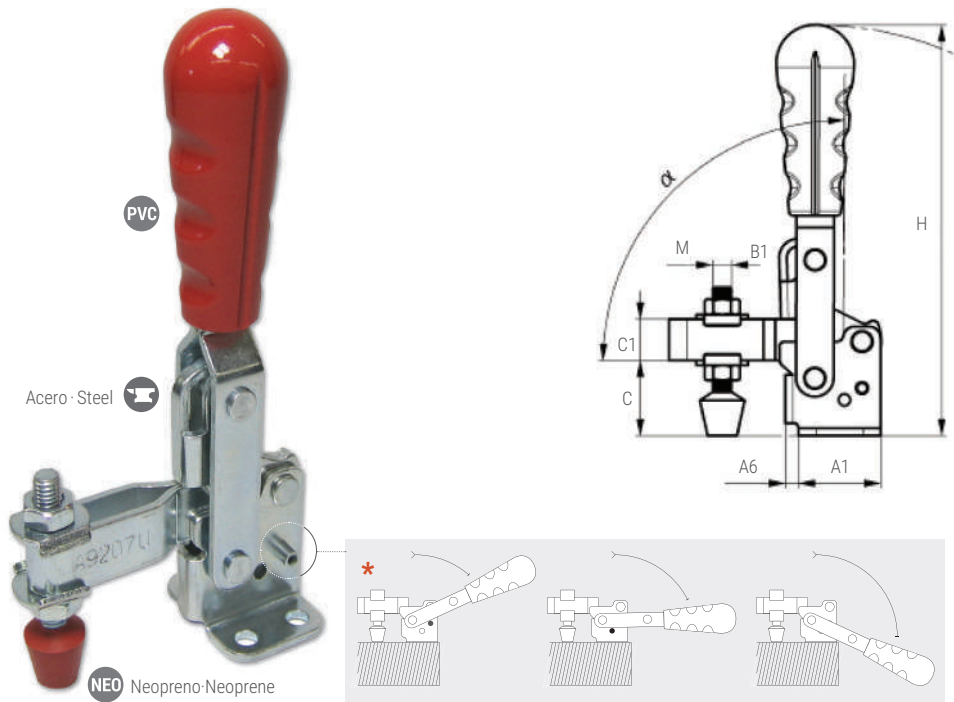

3D Modelos 3D en nuestra web · 3D models in our web

COD	MOD	Kg	FUERZA MÁXIMA MAXIMUM PRESSURE
56001*	M5(201U)	0,05	45Kg
56002*	M6(202U)	0,19	150Kg
56003*	M8(207U)	0,38	250Kg
56004*	M10(210U)	0,81	340Kg
56005*	M12(247U)	1,1	360Kg

COD	A mm	A1 mm	A3 mm	A6 mm	B mm	B1 mm	C mm	C1 mm	C2 mm	D mm	F mm	H mm	L mm	L1 mm	L2 mm	L3 mm	M	α
56001	16	26	5	-	23,4	33,4	19	8	2	4,4	5	77	50,4	24,4	3,5	16,4	M5	67,4°
56002*	12,7	27	7	-	26,9	37,9	23	11	3	5,1	6	111	69,9	42,9	15	21,5	M6	93°
56003*	19	35	8	5,5	32	47	32	17,5	3,2	7,1	8,9	175	90	55	19	28	M8	90,4°
56004*	32	50	9	10	45	64	42	22	4	8,3	10,6	218	143	92,8	23	60,5	M10	90°
56005*	32	50,8	9,5	12,2	45	64	50,8	22,5	3	8,7	13,4	224	176	125	31	82,5	M12	101°

GRAPA RÁPIDA HORIZONTAL · QUICK HORIZONTAL TOGGLE CLAMPS

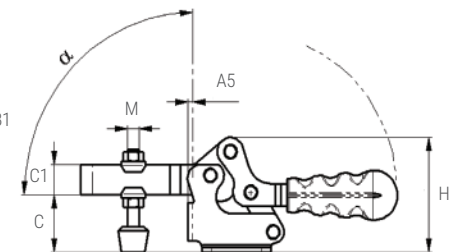
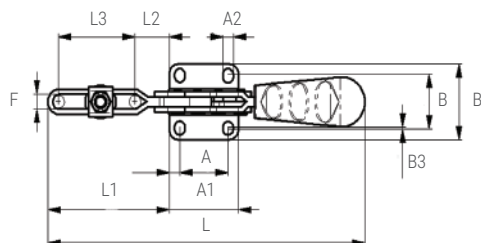

3D Modelos 3D en nuestra web · 3D models in our web

COD	MOD	Kg	FUERZA MÁXIMA MAXIMUM PRESSURE
56050	M4(205U)	0,03	38Kg
56051	M5	0,07	70Kg
56052	M6	0,23	90Kg
56053	M8	0,43	220Kg
56054	M10	0,91	340Kg

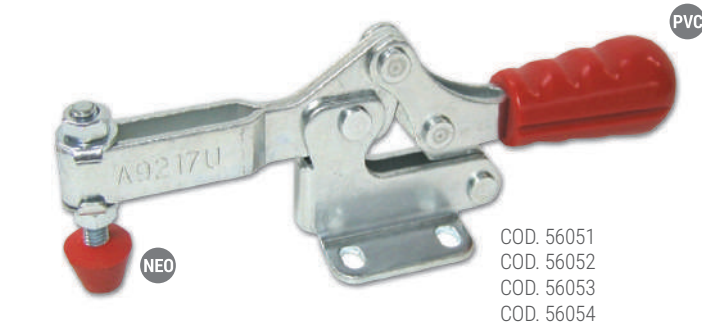

COD	A mm	A1 mm	A2 mm	A3 mm	B mm	B1 mm	B3 mm	C mm	C1 mm	C2 mm	F mm	H mm	L mm	L1 mm	L2 mm	L3 mm	M	α
56050	11,1	24	6,8	4	16	23,8	4,4	7,4	6,8	1,6	4,8	17	68	21	6,5	9,5	M4	87°
56051	13,5	25	5,2	5,7	19	27	-	19	9,5	2	5,8	38,2	105	36,8	12	20	M5	94°
56052	26	38	5,5	6	28	40	3	25	14	2,5	6,2	52,6	162	61,4	19	36,5	M6	96°
56053	26	42	6,6	8	31	47	2,5	34	17,5	3	9	68,5	189	66,3	22	36,8	M8	95°
56054	41,2	59	8,7	9	43	59	1,8	45	23,8	4	11,4	90	269	103	28,5	64,8	M10	95°

INLINE TOGGLE CLAMPS · GRAPA RÁPIDA AXIAL

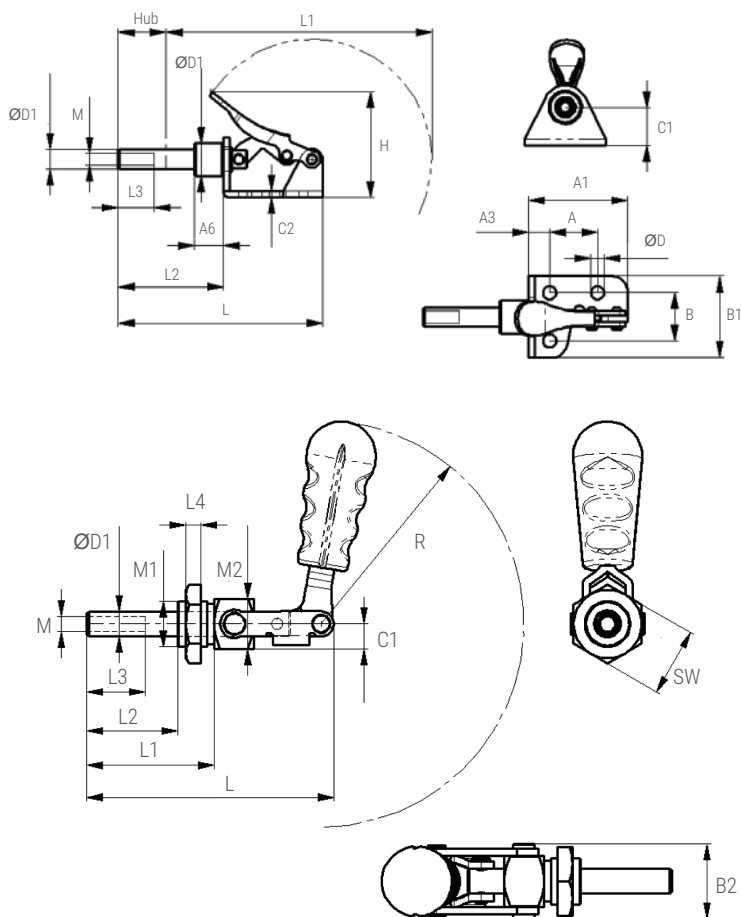

COD. 56100



COD. 56102
COD. 56103

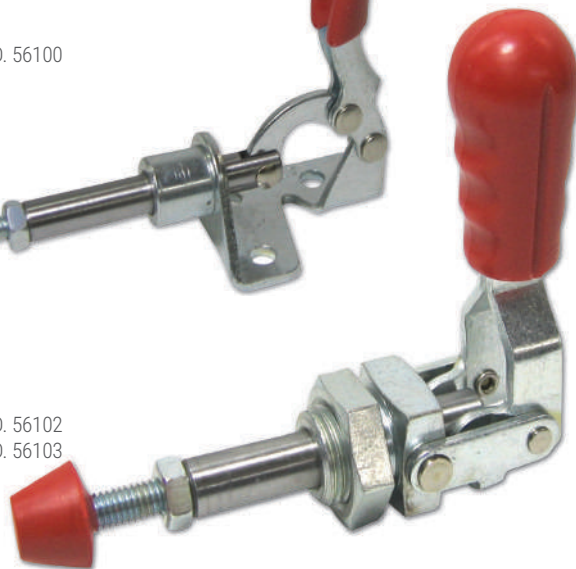

3D Modelos 3D en nuestra web · 3D models in our web

3D	COD	MOD	Kg	FUERZA MÁXIMA MAXIMUM PRESSURE
1	56100	M4 (601 MM)	0,05	45Kg
	56102	M6(602MM)	0,11	90Kg
	56103	M8(604MM)	0,28	130Kg

COD	A mm	A1 mm	A2 mm	A6 mm	B mm	B1 mm	C1 mm	C2 mm	D mm	D1 mm	D2 mm	L mm	L1 mm	L2 mm	L3 mm	H mm	M	Hub mm
56100	16	33	7	10	16	27	12,7	12,7	4,4	6,5	11	68	88,5	35	12	35	M4	16

COD	B2 mm	C1 mm	D2 mm	L mm	L1 mm	L2 mm	L3 mm	L4 mm	Hub mm	M	M1	M2	R mm	SW mm
56102	26	9,5	9,4	64	33,5	20,7	15,8	6,4	19,7	M6	M16x1,5	19	63,3	23
56103	32,6	11	11	104	56	39,7	26	6,4	39	M8	M20x1,5	19	90,5	30

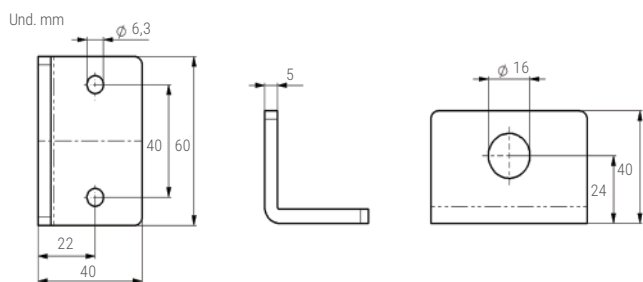

INLINE CLAMP SUPPORT · SOPORTE GRAPA RÁPIDA AXIAL M6

COD	Kg	3D
56112	0,2	1

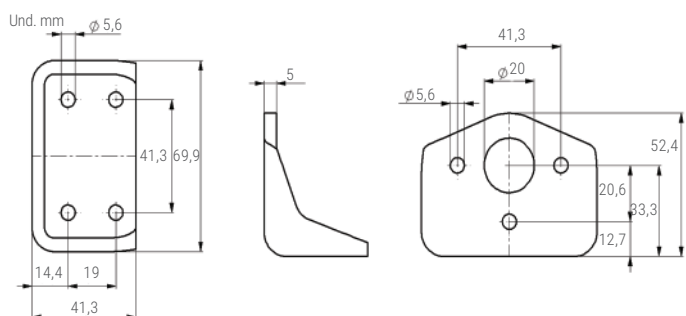

INLINE CLAMP SUPPORT · SOPORTE GRAPA RÁPIDA AXIAL M8

COD	Kg	3D
56113	0,2	1



GRAPAS RÁPIDAS GANCHO · TOGGLE CLAMPS

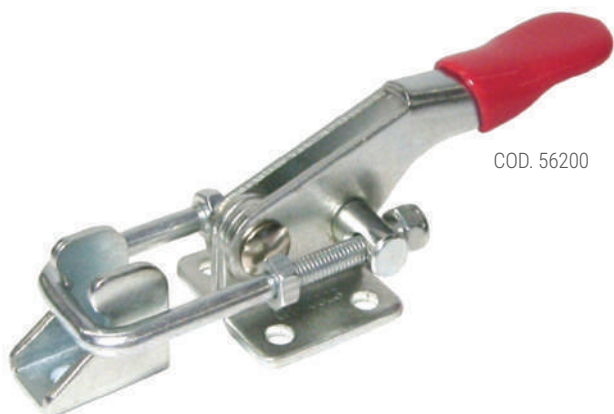

COD. 56200

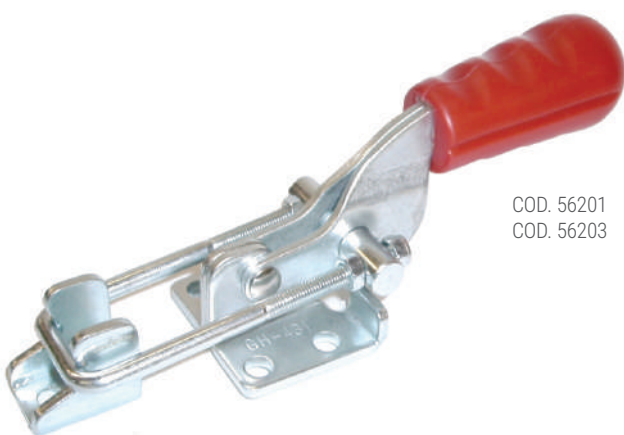

COD. 56201
COD. 56203

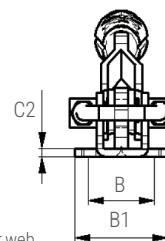
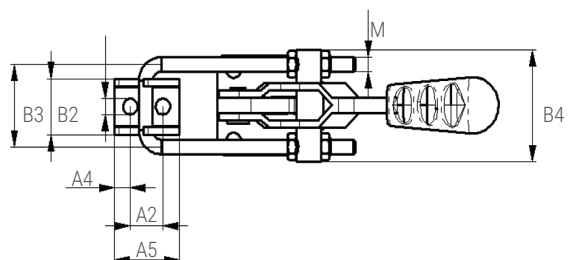
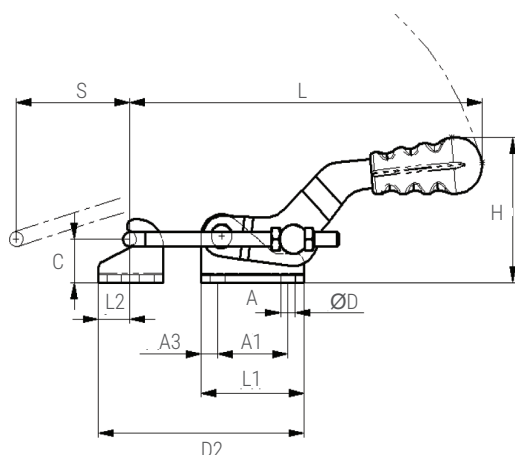

3D Modelos 3D en nuestra web · 3D models in our web

☐	COD	MOD	Kg	FUERZA MÁXIMA MAXIMUM PRESSURE
1	56200	M4 (323)	0,07	160 Kg
	56201	M5 (331)	0,25	320 Kg
	56203	M8 (341)	0,75	700 Kg

COD	A mm	A1 mm	A2 mm	A3 mm	A4 mm	A5 mm	B mm	B1 mm	B2 mm	B3 mm	B4 mm	C mm	C2 mm	D mm	D2 mm	H mm	L mm	L max. mm	L2 mm	M	S mm
56200	16	26	10	5	6	20	19	28	13	19	28	12	2	4,2	4,2	32	96	59	9	M4	27,5
56201	19	39,5	14,3	6,5	5,5	25,3	32	44,5	20	25,5	42	14	3	6,7	6,7	56,5	151	80	12,3	M5	35,5
56203	41,3	60,5	19	9,6	9,5	38	38	54	30	44,5	60,5	23,8	4	8,5	8,5	85	203	118	19	M8	66,5

TORNILLO DE NEOPRENO · SPECIAL SCREW WITH RUBBER BUFFER

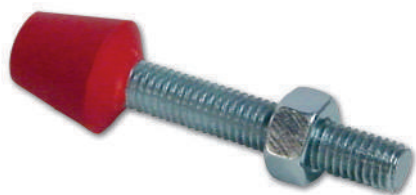

☐	Kg	COD	MOD	Para los artículos For the articles
1	0,03	56900	M4 x 20	56050 · 56100
		56901	M5X30	56001 · 56051
		56902	M6X40	56002 · 56052 · 56102
		56903	M8X50	56003 · 56053 · 56103
		56904	M10X75	56004 · 56054
		56905	M12X100	56005